

Mercury Transit

Innovative World-class Model, Designed for General Applications

TP-702BP (With Press)

Mercury Transit TP-702BP is a fully automatic strapping machine with compression press for production and packaging lines. It is suitable for 5 mm, 6 mm, 9 mm, or 12 mm PP strapping. TP-702BP is the fastest and most reliable strapping machine for general applications on the market today.



15F-1, NO. 17, SEC. 1, CHENGDE ROAD,
TAIPEI 103, TAIWAN
TEL: 886 2 2555 2515
FAX: 886 2 2555 2516
WEB: www.transpakcorp.com
E-mail: transpak@transpak.com.tw

Made in Taiwan

02.2017x1000

Main Features



With Pneumatic Press

TP-702BP is ideal to strap compressible material such as corrugated papers, paper sheets, plastic sheets, bags, etc.

More features refer to TP-702B

Options

- Stainless steel frame (TP-702BPS)
- More options refer to TP-702B

Arch Sizes

(Available with mark ✓)

H	W	550	650	850	1050
500	✓	Ⓢ			
600				✓	
800				✓	✓

Ⓢ Standard size :
650 mm (W) x 500 mm (H)

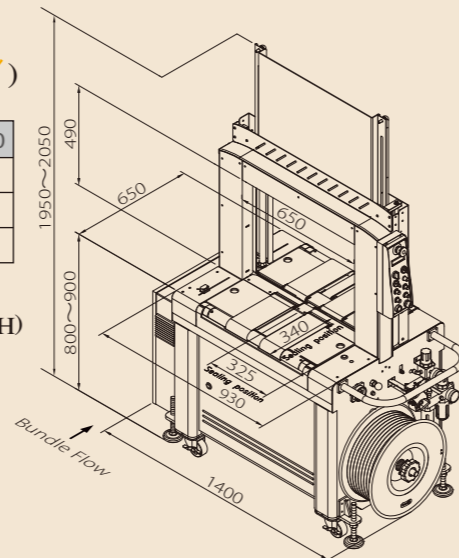

Technical Data

Strap Width	5 mm, 6 mm, 9 mm, or 12 mm
Tension Range	1 - 32 kg (for 5 mm, 6 mm, and 9 mm) 1 - 55 kg (for 12 mm)
Speed	Up to 36 packages per minute (Cycle speed up to 65 straps per minute)
Net Weight	250 kg
Pneumatic Source	6 bar
Air Consumption	7.5 liter/cycle
Electrical Requirements	110V, 220V, 230V, 240V 50/60Hz 1PH 220V, 380V, 400V, 415V 50/60Hz 3PH



All specifications are subject to change without notice.

MERCURY TP-702BP



Mercury Transit is a series of world-class high speed fully automatic strapping machines. These machines offer high reliability and give the best price to performance ratio on the market today.

In this category, we have the following models:

- High speed fully automatic strapping machine with Belt-driven table TP-702B
- High speed fully automatic strapping machine with Belt-driven table and compression press TP-702BP

FULLY-AUTO STRAPPING MACHINE



Mercury Transit

Innovative World-class Model, Designed for General Applications

TP-702B

Mercury Transit TP-702B is a fully automatic strapping machine for production and packaging lines. It is suitable for 5 mm, 6 mm, 9 mm, or 12 mm PP strapping. TP-702B is the fastest and most reliable strapping machine for general applications on the market today.



Main Features



Robust & Compact Mechanical Strapping Head

Mercury Transit uses the latest brushless DC motor technology to provide the highest level of accuracy and reliability. All motors are German-made.

The strapping head has no belts, clutches, or pulleys. It is designed with up-to-date technology with few moving parts. With 30% fewer parts, Mercury Transit requires fewer adjustments, has fewer wear components, and requires less maintenance. The simple design of Mercury Transit minimizes the maintenance cost.



Free Access to Strap Guides (patents registered)

Unlocking the guides enables free and quick access to the strap guides without use of any tools. The most maintenance friendly design.



Electronic Tension Control

The operating control panel with **LCD display** is located on upper side of the machine for easy access. Strap tension can be adjusted accurately by a simple turn of the dial.

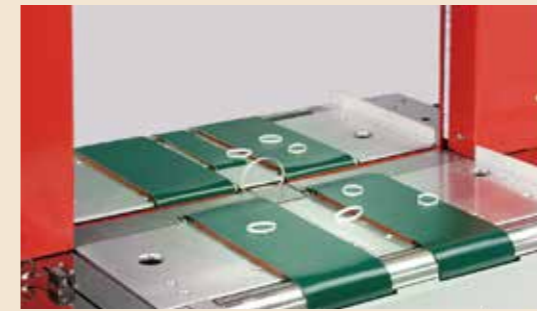

Auto Strap Ejector

Loop-eject clears unwanted strap automatically if the machine is accidentally activated without a package.



Waist-High Auto Strap Feeding

Friendly design to feed the strap automatically from the upper side of the coil without the need to access to the bottom of the machine.



Hinged Top Plates

Opens wide for quick cleaning, inspection, and maintenance of strapping head, strap-feed, and tensioning unit.

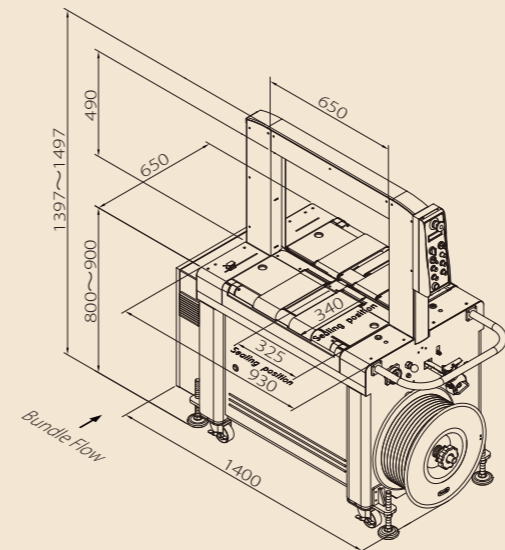

More Features

Multiple Strap Function

For single, double, continuous strapping, or transit mode.

Variable Conveyor Speed

Fully automatic operation with variable conveyor speed between 10 and 60 meters/minute.

Up and Down Stream Interlock

With complete plug connection. Easily integrated into most production lines.

Easy Bundle Flow Direction Change

The bundle flow direction could be reversed easily to meet different production line requirements.

Good to Strap Small Package

The minimum package size is 120 mm in width and 10 mm in height.

Adjustable Table Height

The table height is adjustable to any height between 800 mm and 900 mm.

Options

- **Siemens PLC control**
- Light tree alarm with low strap sensor (triple lamp)
- Energy saving transit with auto sleep mode
- **Strapping in the center of the bundle**
- Extension belt-driven table of 200 mm on upstream and downstream sides
- Lower adjustable table height (750 mm – 900 mm)
- Stainless steel frame (TP-702BS)

Arch Sizes (Available with mark ✓)

H \ W	550	650	850	1050
500	✓	Ⓢ		
600			✓	
800			✓	✓

Ⓢ Standard size : 650 mm (W) x 500 mm (H)

Technical Data

Strap Width 5 mm, 6 mm, 9 mm, or 12 mm

Tension Range 1 - 32 kg (for 5 mm, 6 mm, and 9 mm)
1 - 55 kg (for 12 mm)

Speed Up to 40 packages per minute
(Cycle speed up to 65 straps per minute)

Net Weight 225 kg

Electrical Requirements

110V, 220V, 230V, 240V 50/60Hz 1PH
220V, 380V, 400V, 415V 50/60Hz 3PH